

Frigidaire

INTERNATIONAL

Factory Parts Catalog

Product No.	FGTD18V5GW3
Series	134A SYSTEM
Color	white
Volts	220
Wiring Diagram	240469201
Owner's Guide	241834201
Market	Export
Energy Guide	241981021
Service Data Sheet	240585902
Installation Instructions	240568303

INTERNATIONAL
3 Parkway Center, Pittsburgh, PA 15220

Publication No.
5995528188
08/11/06
(EN/SERVICE/DCS)
390

TOP-MOUNT REFRIGERATOR

Model No.
FGTD18V5G

Copyright © 2008 Electrolux Home Products, Inc.
All rights reserved.

DOOR

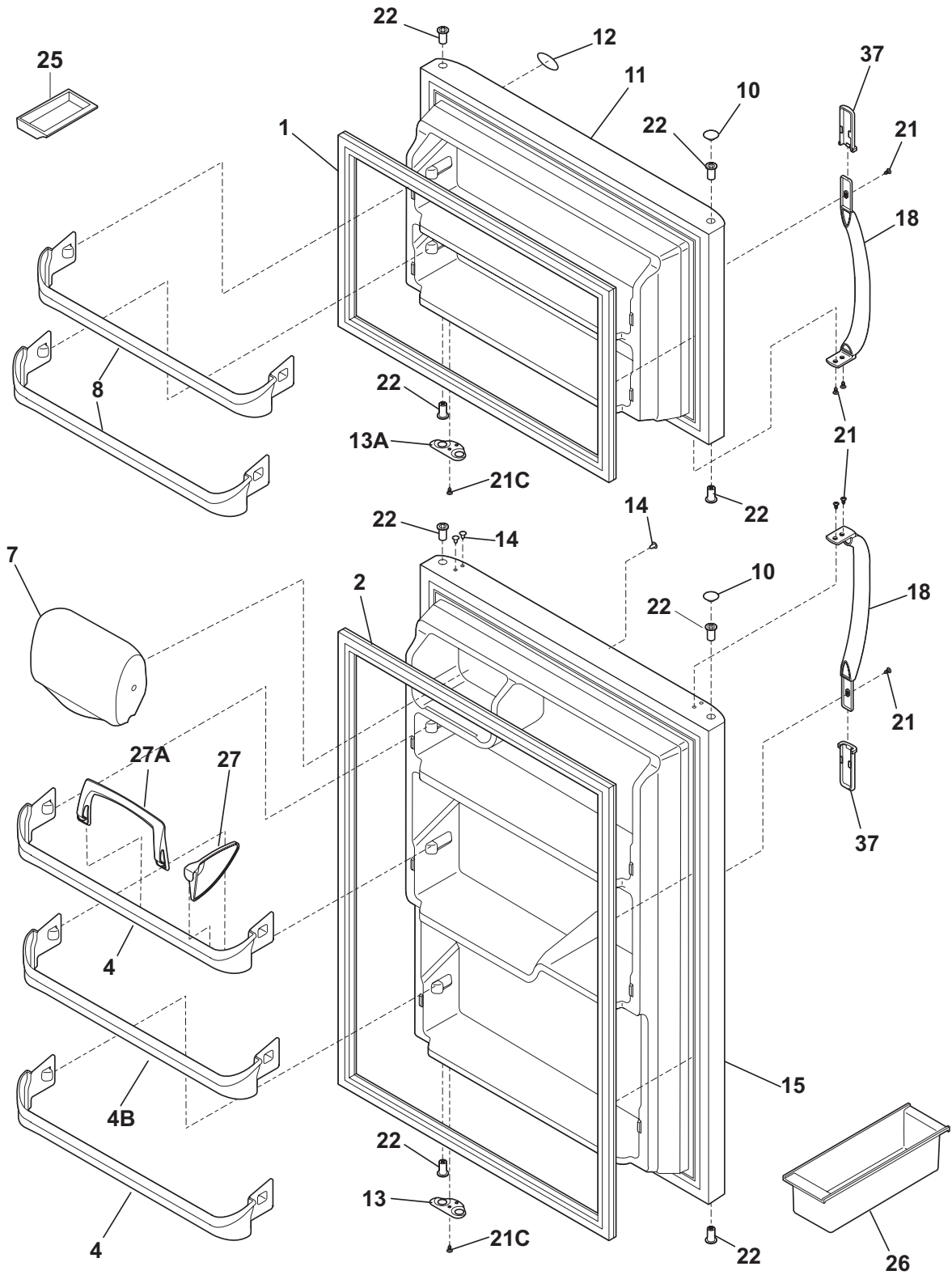

N05DAACKA2

DOOR

POS. NO	PART NO.	DESCRIPTION
1 #	241872501	Gasket-frzr door, white, magnetic
2 #	241872504	Gasket-refr door, white, magnetic
4	240535101	Rack-door
4B	240535201	Rack-door
7	240337717	Door-dairy
8	240535001	Rack-door
10	240381301	Plug-button, white, hinge brg hole, (2)
11	240580402	Door-frzr, white, complete assy
12	241956801	Label-nameplate
13	240312403	Door Stop, white, ref
13A	240312404	Door Stop, white, frzr
14	240494001	Plug-button, white
15	240580602	Door-refr, white, complete assy
18	218668001	Handle-door, white
21	240383406	Screw, truss hd quad, #10-16 x .500, zinc
21C	218252201	Screw, #8 truss hd, 10-32CA x 0.500
22	240527101	Bearing-hinge, natural color
25	5308000716	Dish, butter
26	3204522	Container, egg
27	240396306	Snugger-door bin, "paddle type", water blue
27A	240396106	Retainer-bottle
37	215870629	Trim-handle, 2.47", white, w/satin AL band

CABINET

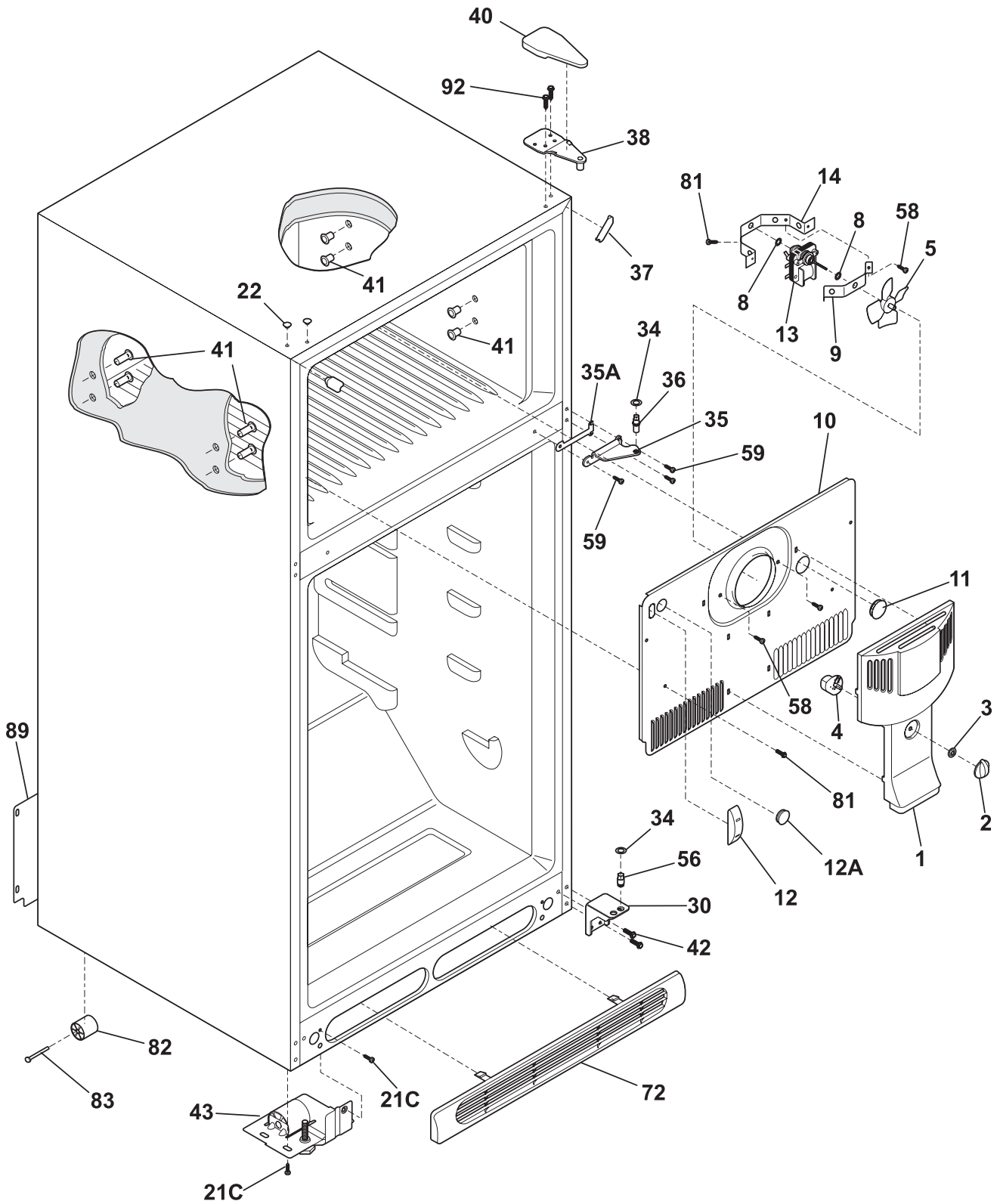

N05BBAABA16

CABINET

POS. NO	PART NO.	DESCRIPTION
1	241652301	Cover-fan
2	240367001	Knob-damper control
3	5303001028	Nut, push-on
4	240367401	Damper-fan cover
5 #	5308000010	Fan Blade, red, evaporator fan
8	5300157666	Bushing-motor mtg, (2)
9	5303292396	Bracket-motor mtg, front
10	241652215	Cover-evap coil
10*	240568601	Seal-coil cover
10*	241832601	Harness-wiring, freezer
11	5303208309	Plug-hole, factory test
12	241557601	Plug-ice maker harness, rectangular
12A	240374401	Plug-wtr inlet tube, round, 1"
12A*	241586701	Plug-foam-wtr-inlet, round
13 #	241832301	Motor-evap fan
13*	215474201	Washer, "slinger", nylon, evap fan shaft
13*	218931001	Clamp-motor wiring, nylon, w/adhesive tape
14	5303292397	Bracket-motor mtg, rear
14*	240433204	Screw, hex washer head, 8-18 x 5/16
21C	218252201	Screw, #8 truss hd, 10-32CA x 0.500
22	215774901	Plug-button, white, upr hinge holes
30	240357106	Bracket-lower hinge
34	240311303	Washer, hinge, nylon, (2)
35	240357006	Bracket-ctr hinge
35A	240336802	Spacer-hinge, center
36	240516402	Pin-center hinge
37	241611301	Trim-cabinet corner, white, (2)
38	240356901	Bracket, upper hinge
40	240354401	Cover-upper hinge, white
41	5308009759	Grommet, shelf mtg, 1.25", LH, (4)
42	240578902	Screw, hex head, 1/4-20 x 5/8
43	241889002	Roller Assy, front LH, (2)
43*	241889001	Roller Assy, front RH, (2)
56	240516502	Pin-lower hinge
58	5304456287	Screw, hex washer head, 8-15A x 0.500
59	240442706	Screw-#10-32 X 3/4, zinc
72	240368301	Grille/Kickplate, white
81	5304455650	Screw, hex washer head, 8-15A x 0.625, low profile
82	5304418225	Roller, compressor base, rear, (2)
83	5304455655	Rivet, flat head, 1/4 OD x 1-3/4, roller pin
89	241736401	Cover-access, w/label
89*	241500304	Screw, hex washer head, 8-18AB x 0.625
92	241710601	Screw, hex washer hd, 1/4 x 7/8, hinge mtg
*	218515401	Clip
*	240479601	Plug, button, cab liner holes
*	5303321319	Paint, touch-up, white

SHELVES

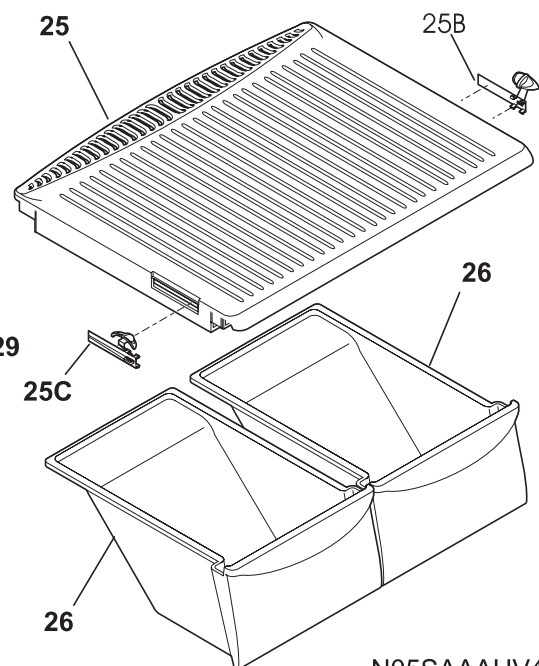
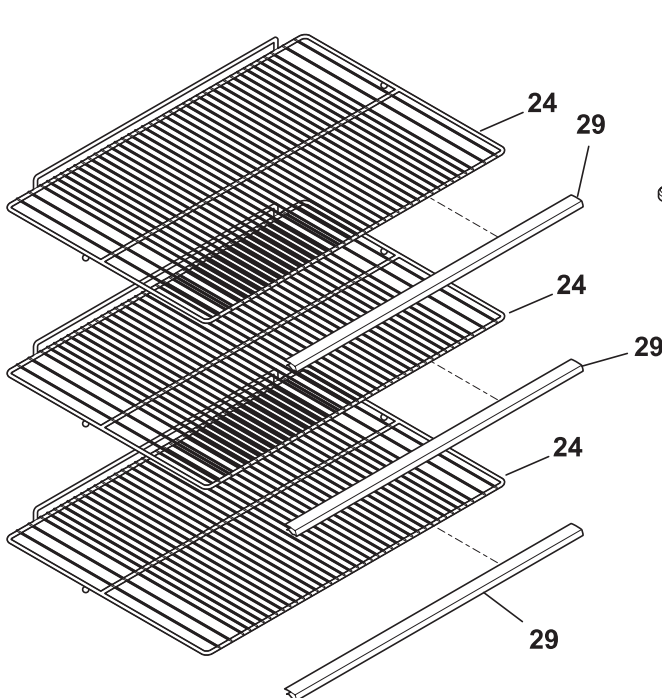
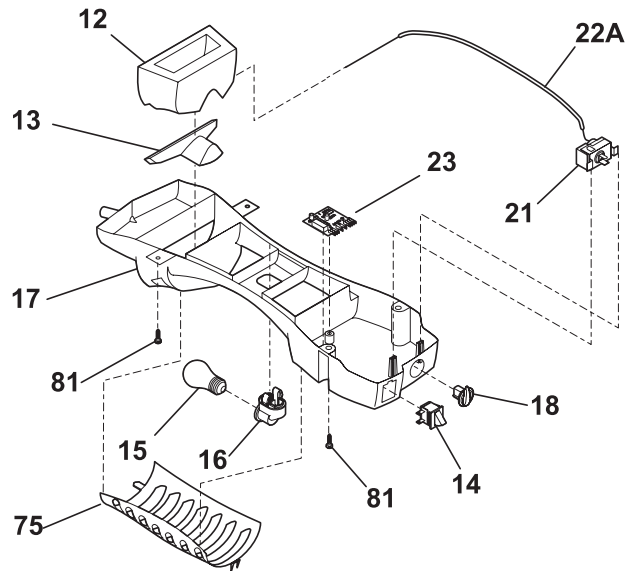
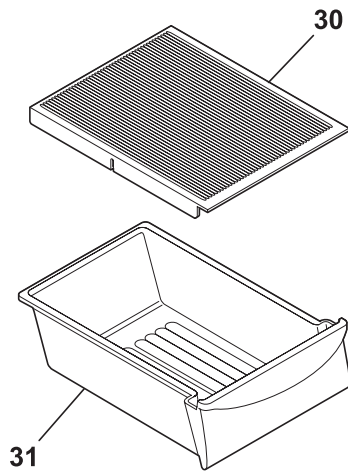
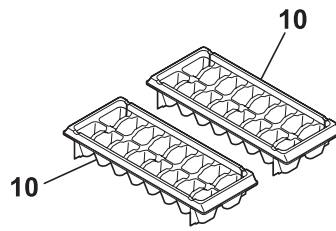
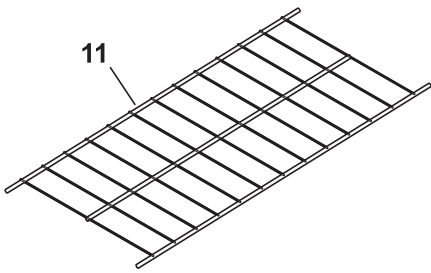

N05SAAHV4

SHELVES

POS. NO	PART NO.	DESCRIPTION
10	215667501	Tray, ice cube, plastic
11	240358004	Shelf, freezer
12	240545001	Diffuser, air, top
13	240362601	Diffuser, air, bottom
14 #	241554901	Switch-light/lamp
15	218814402	Light Bulb
16	240433702	Socket-light/lamp
17	240368002	Control Box
17*#	240375502	Wiring Harness, control box
18	240360801	Knob, temp control
21 #	5304458064	Control-temperature
22A	240468201	Tube, sensor sleeve, 31 inch, plastic, white
23 #	240545405	Control-defrost, adaptive timer, 220/240 V, PC board
23*	5304455649	Screw, pan hd, 6-20 x 0.438
24	240360902	Shelf, sliding, wire
25	240364722	Cover-crisper pan
25B	241613501	Control-humidity, RH
25C	241613502	Control-humidity, LH
26	240364503	Pan, crisper, (2)
29	240430707	Trim-shelf
30	240361801	Cover, meat pan hanger, drop through
31	240530811	Pan-meat, w/o graphics, clear
75	240515601	Shield-light
81	5304455650	Screw, hex washer head, 8-15A x 0.625, low profile

SYSTEM

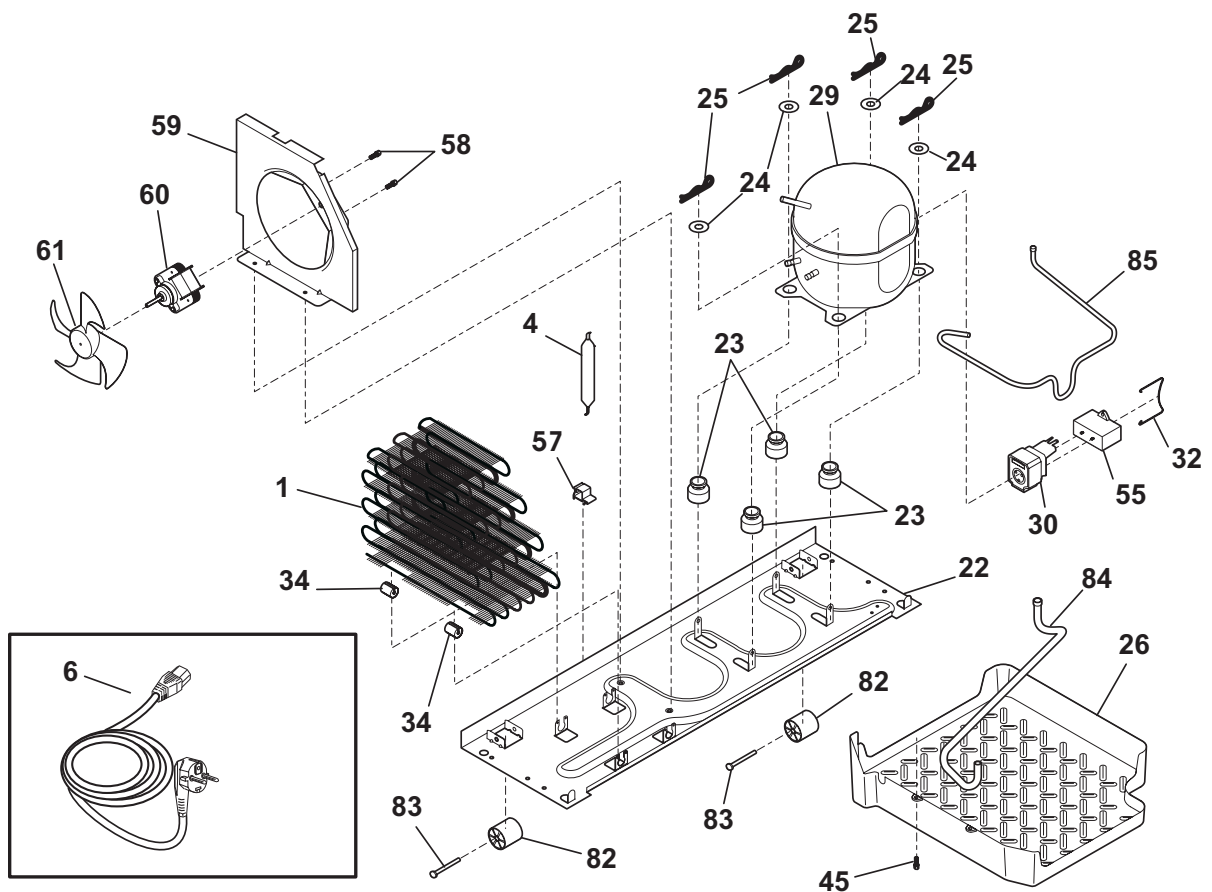
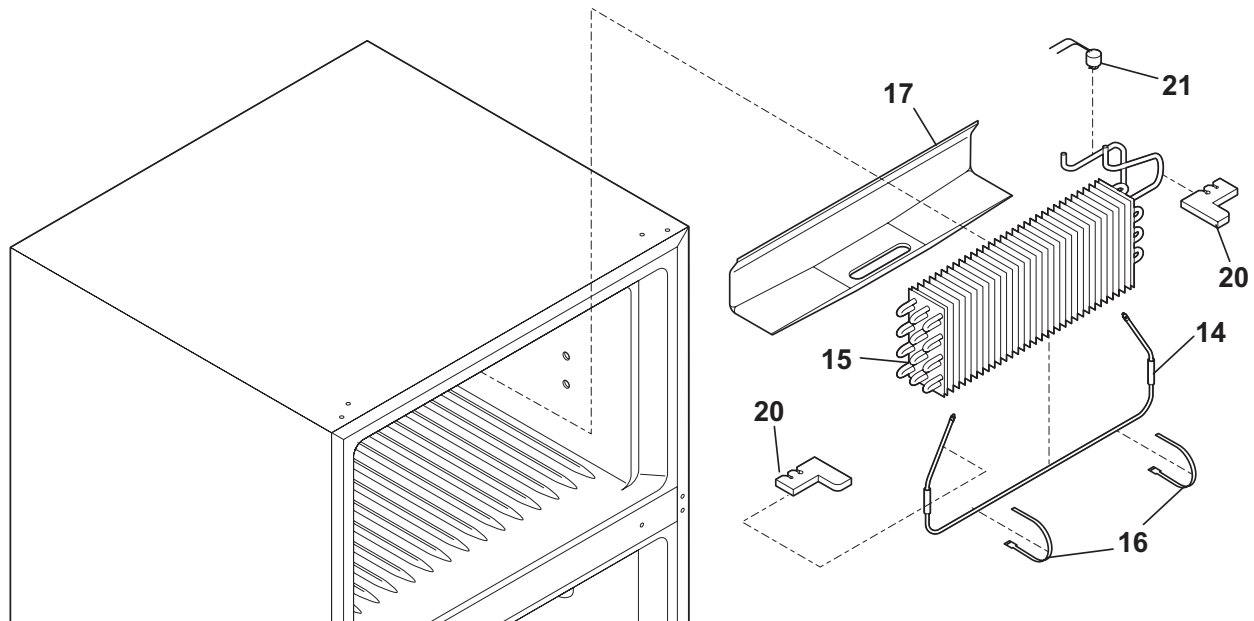

N05CAAABD0

SYSTEM

POS. NO	PART NO.	DESCRIPTION
1 #	241785404	Condenser, dynamic
4	218944002	Drier-filter, R134a System
6 #	241723306	Cord-service
6* #	240375502	Wiring Harness, control box
6* #	241627201	Harness-wiring, machine compt
6* #	241735901	Bracket Assembly
6* #	241832601	Harness-wiring, freezer
6*	240451503	Screw, ind hex wshr hd, 8-32 x 0.375, trilobe
14 #	240356223	Defrost Heater, 220 V
15 #	5303918275	Evaporator Kit
16	5308000110	Strap-evap/heater, aluminum, (2)
17	241801302	Trough-drain
20	241551902	Insulation Block
21 #	5303918202	Thermostat-defrost, kit
22	241665605	Base-compressor
22*	218252201	Screw, #8 truss hd, 10-32CA x 0.500
23	218513300	Grommet-compr mtg, (4)
24	241812301	Washer-compr mtg
25	216056401	Clip-compressor mtg
26	241683601	Pan-defrost
29 #	5303918413	Compressor, w/electricals
29*	240433204	Screw, hex washer head, 8-18 x 5/16
30 #	241707714	Starter-PTC
32	241544101	Clamp, elec cont mtg, compressor, bale wire
34	240405201	Grommet, rubber, black, cond tube/wire
45	241500304	Screw, hex washer head, 8-18AB x 0.625
55 #	218909908	Capacitor, run
57	240542601	Clip-wiring harness
58	218897002	Screw, hex washer head, 8-32 x 0.375
59	241935602	Shroud, cond fan motor
59*	240346701	Tape-foam seal, shroud
59*	240359403	Screw-fan shroud, (2)
60 #	241696603	Motor-condenser fan
61 #	240524102	Fan Blade, condenser fan
82	5304418225	Roller, compressor base, rear, (2)
83	5304455655	Rivet, flat head, 1/4 OD x 1-3/4, roller pin
84	240359601	Tube-drain, lower
85	241856901	Tube-connector, suction
*	240396801	Clamp, tube/wiring, nylon, black/natural
*	5303918263	Heat Exchanger Kit, suction line
* #	5303918241	Hot Tube Repair Kit, 220 V, service

WIRING SCHEMATIC

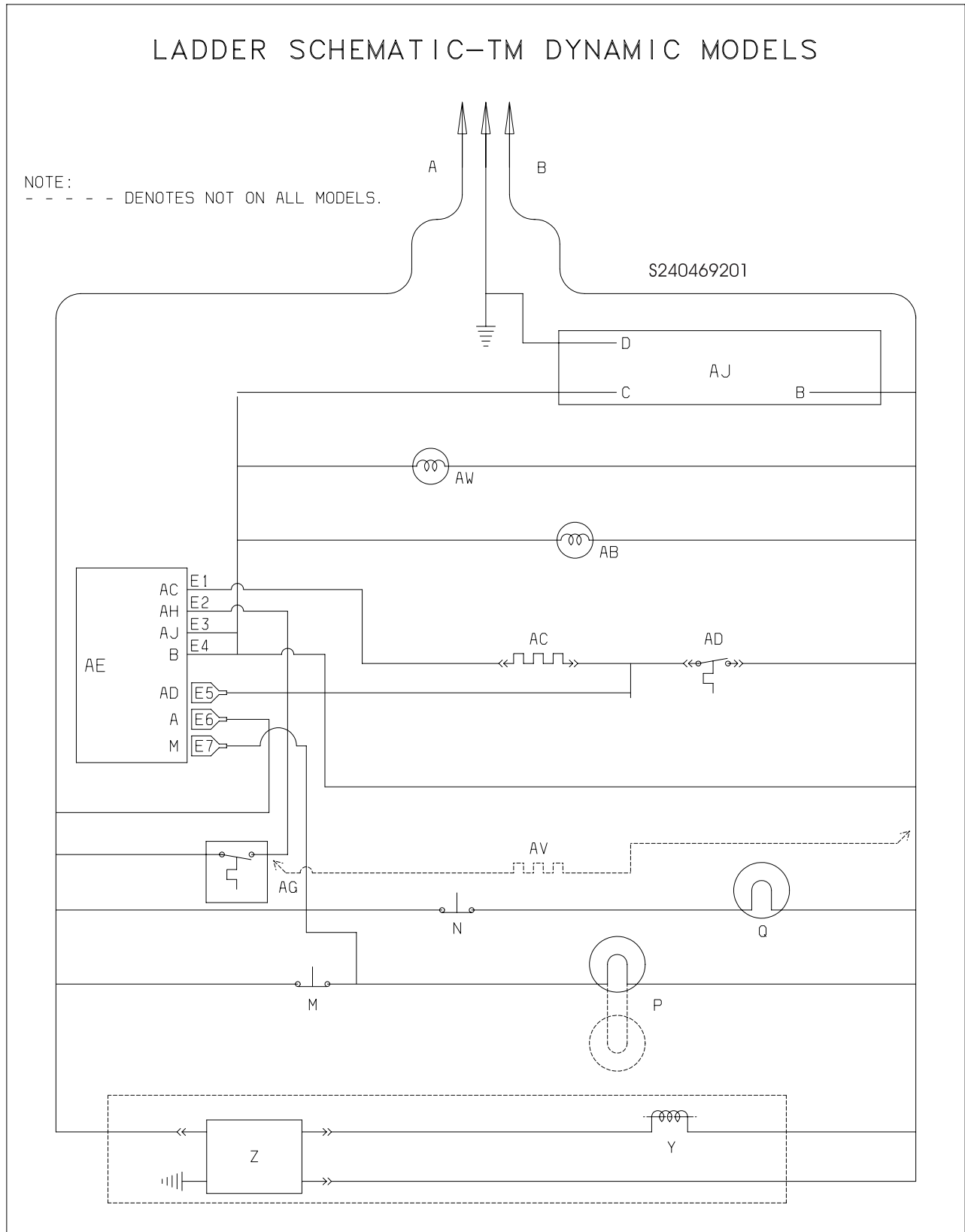

WIRING DIAGRAM

